

The first major change in years in amplifier coupling circuit principles is discussed, together with details of the components employed.

FRANK H. McINTOSH*
and
GORDON J. GOW*

Description and analysis of a

New 50-Watt Amplifier Circuit

AUDIO AMPLIFIERS—being one of the oldest forms of equipment built using the three or more element tube—are now one of the most difficult devices to improve, and perhaps no other field of electronic endeavor has been given more time or has been studied by more people. One of the major reasons sound amplifiers are difficult to design is the requirement for very wide frequency range, highest to lowest running up to 20,000 to 1 in order to meet the ever increasing demand for more faithful reproduction of

3,000 cps and higher the shunt capacitance across the primary circuit of output transformers becomes one of the major limiting factors, regardless of the mode of operation of the output stage. When the output stage is operated Class AB or Class B to improve the efficiency, then an additional problem growing out of the switching from one side of the circuit to the other in the output stage and thus producing a transient has been a barrier for over 20 years and has made practically useless such circuits except in applications where the harmonic content was not of great importance or where the range was limited over which such circuits are operated. This transient appears as

the ear to detect distortion, the range and power of speech and musical instruments, the impulse characteristics of sound, the load impedance variations and effects of loudspeakers and other devices. A treatment of these basic requirements must be reserved for a later discussion.

Output Circuit

Figure 1 illustrates the output circuit of the conventional pushpull amplifier in simplified form. It will be seen that the plates are connected in the conventional way to the primaries of the output transformer and the resistor forming the load is shown connected to the secondary. The plate-to-plate impedance in this circuit is 4000 ohms. This is about right for a pair of 6L6's as used in the McIntosh 50W-1 amplifier. Attention is called to the 1000-ohm impedance which corresponds to the circuit from the plate to the center tap of the primary of this output transformer. These impedances should be borne in mind as later reference will be made to them as part of

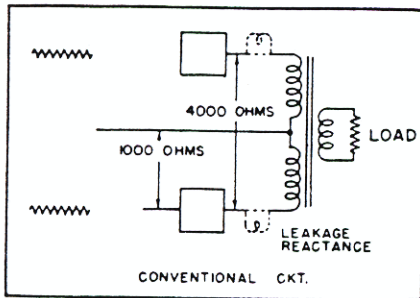

Fig. 1. Simplified output circuit of conventional push-pull amplifier.

audio range of from 18 to 20,000 cps. This wide range is probably the most rigid requirement for any electronic device regardless of its use. To satisfy the design requirements for an audio amplifier, several problems must be overcome. At the low end of the audio band the requirement for sufficient core material of proper magnetic properties must be weighed against core loss, weight, size, and expense. These quantities bear an inverse relationship to the total number of turns, but the total turns bear an inverse relationship to the leakage inductance and the effective shunt capacitance. At frequencies of

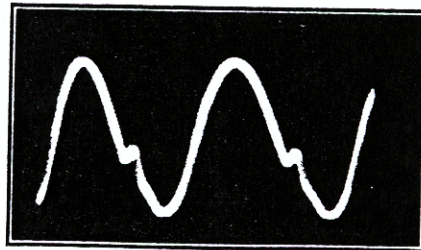

Fig. 2. Oscilloscope trace showing notches in output wave when operating between Class A and Class B.

a notch in the signal wave form and was first described in 1936¹ but for which no solution was suggested beyond that of reducing the leakage inductance of the output transformer or of biasing the amplifier stage back to Class A operation.

The basic circuit which we are about to describe grew out of an attempt to meet many considerations and requirements based upon tests and measurements made concerning the ability of

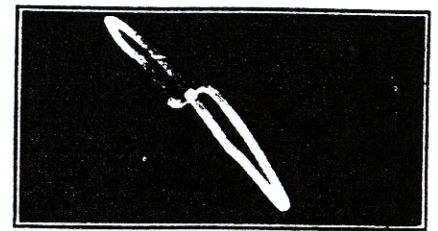

Fig. 3. Trace showing transfer characteristic of output tubes with discontinuity due to notch of Fig. 2.

the description of the new circuit. In the discussion to follow it is assumed that each of the tubes in the output circuit alternately cease to draw current during a portion of the audio

*McIntosh Engineering Laboratory, Inc.
910 King Street, Silver Spring, Md.

¹ A. P. Sah Quasi-Transients in Class B Audio Frequency Push-Pull Amplifiers, Proc. IRE, Nov. 1936.

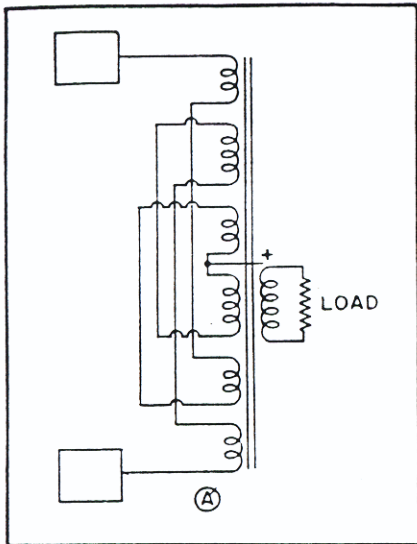

Fig. 4. One method of minimizing leakage reactance by use of sectionalized primary winding.

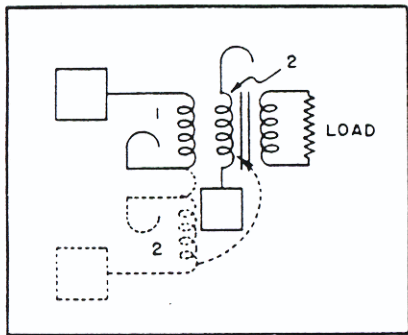

Fig. 5. Simplified form of new coupling arrangement for amplifier output stage.

cycle and, therefore, are operated somewhere between Class A and Class B.

Experience has shown that using the circuit of Fig. 1 and operating between Class A and Class B will result in a deformity, appearing as a "notch" as shown in Fig. 2 for all frequencies above approximately 2,000 to 3,000 cps. This waveform distortion measures 2 to 10 per cent or more depending upon the frequency and the leakage reactance existing between the two primary windings. This "notch" occurs because there is a residual leakage inductance in the plate circuit of each of the output tubes which becomes a source of voltage independent of that voltage driving the stage at the instant when one tube ceases to draw current and the other tube draws more current. This residual inductance or leakage reactance acts like an inductance through which the current has suddenly been cut off, and it generates a back e.m.f. which distorts the output wave. The value of this leakage reactance must be minutely small so that the distortion of the wave form at the highest frequency will not exceed 1 per cent. This effect has no panacea, so far as we know.

Negative feedback, the usual panacea,

does not improve the situation, as might be expected, but rather tends to make it worse. To cancel the notch in the waveform a current flow would be required through the tube in the reverse direction to that which the electron flow permits, at the time the tube ceases to draw current during the normal cycle of operation. Another way to describe what happens in the circuit is to consider Fig. 3. Here is shown an oscillographic trace of the transfer characteristic of the output tubes. The presence of leakage reactance causes a discontinuity to exist in this characteristic. This is the barrier which has been the source of frustration of many engineers for years past and is perhaps the major reason that high efficiency and low distortion could not be made compatible.

Reducing Leakage Reactance

There are a number of approaches aimed at reducing the leakage reactance but the penalty has been so great that the value of the increased coupling between primary windings has been offset sufficiently to make these approaches no solution at all, or of little value. Figure 4 shows symbolically the sectionalizing of the two primary windings shown in Fig. 1. Here the primary is made up of many coils which are connected in such a fashion as to tend to make all the windings occupy the same space. This is an effective means of increasing the coupling between two coils and does increase the frequency at which the "notch" first appears. However, this approach has the disadvantage of increasing the shunting capacitance effects between the two plates of the circuit to such an extent that the high frequencies are by-passed. There doesn't seem to be any practical way to sectionalize and interleave these windings to eliminate the leakage reactance effect

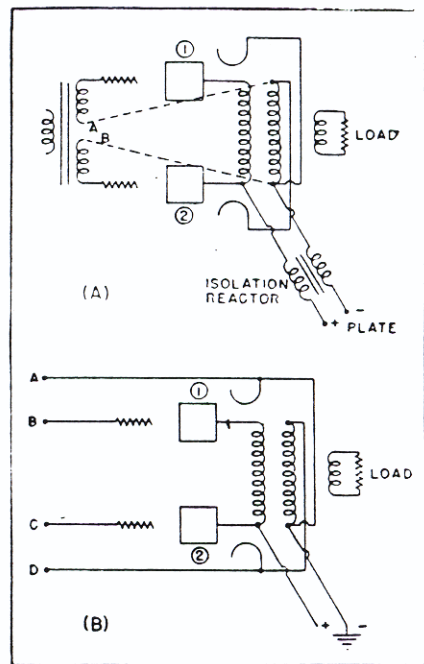

Fig. 6. Steps in development of coupling circuit.

and at the same time avoid the shunt capacitance effects. Another method which suggests itself as a result of the experience just described is to use a much larger core, permitting a reduction in the number of turns required in the windings of the primary circuit. This approach requires a very large core in the order of 125 pounds to effect a sufficient reduction in leakage reactance. This compares very unfavorably with the 11-pound core required in this new unity coupled output circuit for the same performance. It may be well to mention here also that the use of a large core has several other disadvantages among which is higher distortion, particularly at low output levels. This is due to the non-linear characteristics of the magnetic material and the relative-

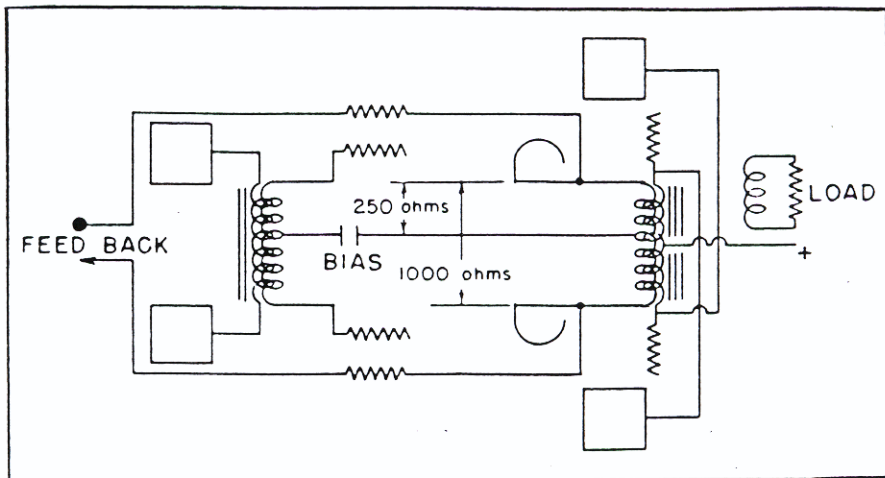

Fig. 7. Final basic arrangement employed to provide d.c. voltage for screen grid, but at the same a.c. potential as the corresponding cathode.

is larger total loss in the larger core. It would be well to point out at this time that for 6L6 tubes operated in Class AB or Class B, the ratio of inductive reactance of the primary of the output transformer to the leakage reactance between the primaries must be 80,000 to one or greater to permit 1 per cent distortion at 20 kcs and full output to as low as 20 cps.

From the above discussion it seems impractical to reduce the leakage reactance sufficiently to permit high-efficiency operation and the only hope, therefore, is to go back to a conventional Class A arrangement where a discontinuity in the current drawn by each of the tubes does not occur over the operating cycle. The solution for high efficiency operation requires an unconventional circuit which will effectively eliminate the leakage reactance between the primary windings.

Figure 5 illustrates the approach made to circumvent the problems described above. The conventional output primary circuit is again shown with the primary marked 2 in dotted form. For simplicity the power supplies are eliminated and the midpoint of this primary is shown connected to the associated cathodes. The solid position of primary 2 is shown adjacent to primary 1 and this illustrates the first step in the development of the unity coupled amplifier. These two primaries are wound

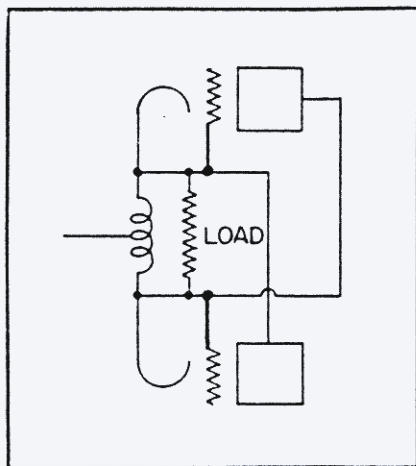

Fig. 8. Equivalent circuit simplified from Fig. 7.

together in a bifilar manner as if they were one winding and, therefore, there is between them both a capacitance coupling turn by turn, and a magnetic coupling due to the presence of the common core. Since the wires occupy practically the same space, the coupling is exceedingly high and measurements show that it is practical to wind coils with a ratio of primary inductance to leakage reactance much better than 2000,000 to 1. This, therefore, provides a way to eliminate the leakage reactance which in conventional transformers far exceeds the minimum ratio requirement

of 80,000 to 1. We now, therefore, have a system which appears to have promise by reason of finding a way to eliminate the leakage reactance between the primary windings which in turn removes the barrier which has blocked for so many years the use of high-efficiency circuits in high quality audio amplifiers.

It is obvious that other variations of approach have been considered which accomplish the desired purpose to some extent at least, such as winding the two primaries on a common core not bifilarly and utilizing a suitable capacitance for coupling the ends of these windings so as to maintain the two windings at proper and identical a.c. potentials. One advantage of the bifilar winding is, of course, a reduction of the number of components required, and it sidesteps some of the difficulties which grow out of the use of alternate approaches. It may also be obvious here that since the two primary windings are unity coupled there is no longer any need for sectionalizing the primary as is common in high quality transformers today. This results in an economy in manufacture.

Circuit Arrangement

To make Fig. 5 a practical circuit, the cathodes are connected to one coil and the plates to the other coil without changing their position in the circuit from an a.c. standpoint but permitting

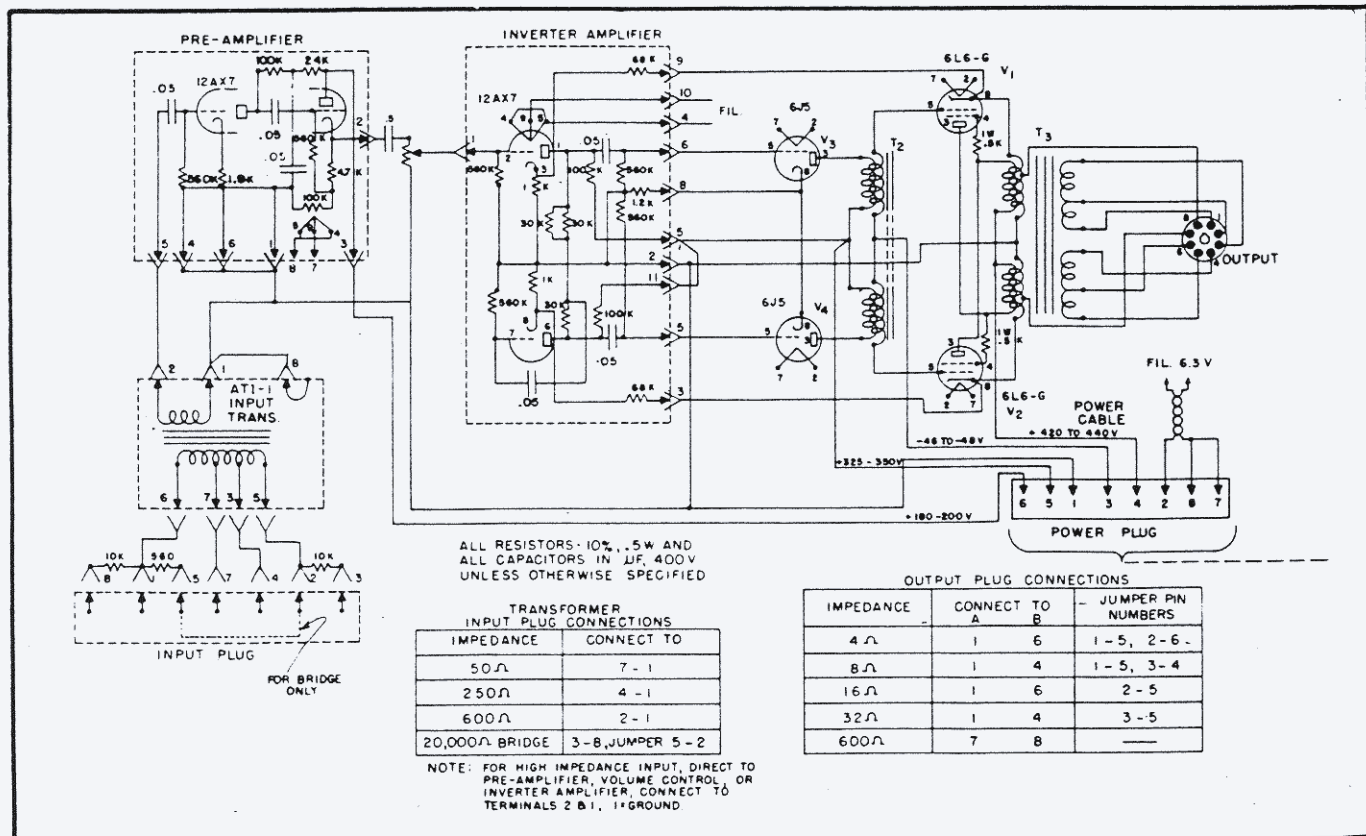

Fig. 9. Schematic of McIntosh 50W-1 amplifier.

50-WATT AMPLIFIER

the application of the d.c. plate supply between these coils.

Figure 6 (A) illustrates a further step in the development of the final circuit and shows a cathode-loaded arrangement with a required plate supply isolation reactance. Here it will be seen that the cathode loading results from the method of drive. For instance, tube 1 is driven from the control grid to the far side of its load which is, from an a.c. standpoint, at the same potential as its plate, and similarly tube 2 is driven in a like symmetrical manner. In order to drive the stage, it is necessary to do two things: to provide an input transformer or similar device and to provide an isolation reactor which has sufficient impedance to keep the plate supply and the amplifier stage isolated from an a.c. standpoint. It will be seen here that the entire stage is floating with respect to ground. At points A and B in Fig. 6(A) it will be noted that the full voltage developed across the output stage appears to add to the difficult problem of designing a driver transformer able to handle the large voltages needed to drive the output stage. These difficulties—as well as the requirement for wide frequency range, balanced coupling, and high impedance primary—make this transformer somewhat impractical if not impossible.

Deleting the isolation reactors from the circuit of Fig. 6(A) gives the circuit of 6(B) in which the two cathodes remain at the signal potential difference of the output transformer primary, but one cathode has been returned to ground while the other is left floating. Again the design of an input transformer is highly impractical.

An attempt, therefore, was made to get away from the four-terminal input circuit required by Fig. 6(B) and go back to the conventional three-terminal input if at all possible. This was accomplished by the circuit as illustrated in Fig. 7, which is similar to those of Fig. 6 except that instead of driving the stage fully cathode loaded, the point A of Fig. 6(A) was connected to the mid-point of the cathode winding which, of course, suggested that point B be connected to that same cathode mid-point. We now, therefore, have our three-terminal conventional drive circuit, and furthermore we find that this mid-point can be grounded, which immediately suggests that the plate supply can be similarly attached to the mid-point on the plate winding of the output transformer, and finally this elimi-

nates the need for the isolation reactors.

Concentrating first on the output transformer primary and taking for instance the a.c. current path from the

screen. Figure 8 illustrates a simplified equivalent circuit of Fig. 7 that may clarify the use of the 'take turn' primary idea.

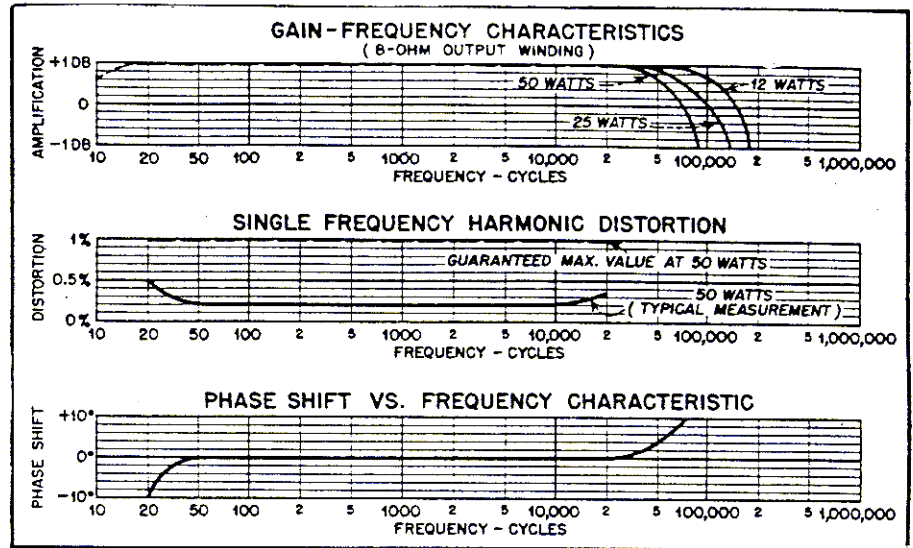

Fig. 10. Performance characteristics of 50W-1 amplifier.

plate supply at + upwards through the winding and to the plate of the lower tube, thence from its cathode through its winding to the center point and therefore back to the power supply, we have utilized one plate winding and one cathode winding on opposite halves of these coils. Considering the upper tube, we find a similar situation. It is seen that half of the output winding is in the cathode circuit and half is in the plate circuit for each tube, but since the two windings are coupled tightly from an a.c. standpoint, they become practically identical, and therefore we have an output stage which utilizes essentially the same primary windings. Since this is so, it is obvious that there can be no leakage reactance between the output coils for the two tubes. In addition to the compatibility now possible between high efficiency and high quality, there are several other advantages of this circuit arrangement which are described.

Circuit Advantages

It is convenient with this circuit to use either pentodes or triodes. Figure 7 shows the screen grid connected in a suitable manner to make use of the inherent efficiency in power conversion of pentodes or beam power tubes. The requirement that the screen be kept at a constant d.c. potential with respect to the cathode is fully met by virtue of the fact that the two windings are coupled so tightly that no a.c. potential can develop between the cathode of either tube and its corresponding screen. It is obvious also that a constant d.c. potential equal to the plate voltage, in this case, is provided for the

Referring back to Fig. 7, some of the additional advantages of these circuits will be described. The impedance between the tubes is now 1000 ohms instead of 4000 ohms shown for the conventional circuit in Fig. 1. The impedance between either side and ground is only 250 ohms instead of 1000 ohms. This 4-to-1 impedance reduction between the tubes reduces the effects of stray capacitances by a factor of 4, permits a wide extension of the audio pass band, and reduces the phase shift of the fundamental and the harmonics. Furthermore, since the two primary windings now look like one winding to the secondary, the effective turns ratio has been reduced by a factor of 2 to 1 between primary and secondary. This results in a 4-to-1 coupling advantage over the circuit shown in Fig. 1. Since both the shunting capacitance impedance advantage of 4 and the coupling advantage of 4 occur simultaneously, there is inherently a 16-to-1 advantage in this circuit over the conventional circuit. This advantage obtains regardless of the class of operation of the tubes. Therefore, not only has the barrier been crossed to permit the use of high efficiency at low distortion, but at the same time a substantial improvement in circuit characteristics has been found.

Figure 7 also shows that some direct-coupled negative voltage feedback is used. It will be seen that since half of the load is in the cathode and half of the load is in the plate, as before mentioned, almost the entire gain in this final stage is lost by virtue of the feedback resulting from this method of loading. Additional feedback is achieved

by connecting suitable resistors between the cathodes of the output tubes and the cathodes of the phase inverter stage. This combination of feedback results in improving the linearity of the amplifier and permits the manufacture of amplifiers on a regular production basis which can be guaranteed to have less than 1 per cent distortion over a wide range of frequencies.

This feedback also reduces the internal generator impedance to a value approximately one-tenth of the referred load impedance. This means that the output circuit, say the 8-ohm winding, looking back into the amplifier would be 8/10th of an ohm. This low generator impedance provides two desirable characteristics.

Low Output Impedance

It is obvious that if the impedance of the load device—such as a speaker—should change, as it usually does over the range of frequencies for which it is used, then the effective amplification will likewise change, resulting in a limitation of the power output or serious distortion, or both. Therefore, it is important in the design of an amplifier that is to be used anywhere but on a test bench and working into a resistance load, that it should be made as free as possible of the effects of load impedance in order that the design performance of the amplifier can be realized in actual practice. The 50W-1 amplifier for all practical purposes isolates the effect of the load on the effective amplification of the output stage because of this low value of generator impedance. Furthermore, the tendency of the load device to continue motion after the initiating signals have ceased is effectively damped. This means that any back e.m.f. generated by the load device sees such a low resistance looking back to the amplifier that the counter e.m.f. resulting from this low resistance dynamically brakes the load device and quickly damps out any free oscillation. Theoretically there is no minimum limit to which this internal generator impedance can go to act as a benefit in both of the principles above mentioned. However, going from the damping factor of ten to zero for the use in audio devices produces only a minute improvement in damping since the load devices do not approach 100 per cent efficiency. For some applications the internal generator impedance has been made 1/100th of the nominal impedance.

One of the apparently conventional features of the amplifier is the driver transformer for the output stage. Since the direct current drawn from the power supply by the Class B stage is proportional to the input signal level, and

since the power supply internal resistance can not economically be made to approach zero ohms, there will be a change in plate voltage with a change in input level. At best, change in level of a single-frequency signal from zero to full output, the change in plate voltage cannot be made less than 25 volts. If the driver plate voltage were to be derived from this varying source and the driver were resistance-capacitance coupled to the control grids of the Class B amplifier tubes, the change in plate voltage would appear as a change in bias adding to the bias for an increasing signal and subtracting from it for a decreasing signal. A 15- to 30-volt increase in bias voltage would shift both output tubes toward Class C operation and consequent current cutoff during both crossover periods for a length of time depending on the duration of the change in level and the time constant of the resistance-capacitance coupling circuit. The increase in bias signal level change will appear as transient distortion. To avoid this source of distortion either separate power supplies or transformer coupling is required between the driver and the output stage. The design of a high-impedance push-pull transformer along conventional lines is another impractical problem. To keep waveform distortion and current consumption low in the driver stage, the primary impedance of the driver transformer must be kept above 100,000 ohms from 20 cycles to 30,000 cycles. The response of the transformer from primary to secondary should not show more than a 0.1 db variation from 18 cps to 30 kcs in order to function within a second feedback path in the amplifier. All of these requirements were met by resorting again to the bifilar construction where the input windings are wound together, giving practically 100 per cent coupling independent of frequency.

Figure 9 shows the schematic diagram illustrating the 50W-1 watt amplifier including the phase inverter, volume control and preamplifier. It will be seen from this circuit that the driver output stages are similar to those diagrammed in Fig. 7. The output transformer provides for 4, 8, 16, and 32 ohms balanced or unbalanced, as well as 600 ohms balanced. It will be noted that the 600-ohm tap is taken off the primary winding connected to the cathodes of the output stage, and since this winding is grounded at its midpoint, neither of these taps (7 and 8) can be grounded. If required, a 600-ohm winding can be supplied separate from any of the other windings of this transformer.

The amplifier is designed in a man-

ner similar to that described for the power supply, namely, that the driver coil and output coil are potted in the box forming the unit, that the top includes a number of sockets which are interwired to provide the proper circuitry and the other elements plug into these sockets to provide the proper amplifier arrangement. This permits easy "substitution method" servicing, fixes the relative position of components, providing for better uniformity in manufacture and permits unusual arrangement features. For instance, the input level to the amplifier is approximately zero db when connected into the phase inverter. The plug-in "preamp" provides an additional 34 db gain, and a triple-shielded input transformer provides an additional 20 to 30 db depending on which input connection is used 30, 150, 600 ohms or bridging input. A control console is available which includes tone control, additional preamps and necessary switching for microphone, phonograph, and radio inputs. An equalizer-amplifier which follows the NAB recording curve and with a gain of 20 db at 1,000 cycles may be plugged into the unit.

Figure 10 illustrates the average performance characteristics of the amplifier. The gain-frequency characteristics may seem abnormally wide, but since it was desired to provide a manufactured product which could be guaranteed to deliver 50 watts at any frequency from 20 to 20,000 cps with less than 1 per cent harmonic or intermodulation distortion, this wide band was found necessary to keep the phase shift reasonably low so that the feedback of the higher fundamental frequencies and their harmonics would be in proper phase relationship to cancel out, and therefore improve the linearity of the amplifier. If the phase shift at the pertinent harmonics is 90 deg. or more, no benefit is obtained from feedback, and since the feedback varies inversely from one at zero deg. phase shift to zero at 90 deg. approximately as the cosine of that angle, it is seen that quite large phase angles are associated even with relatively small losses or variations in the gain-frequency characteristic. For instance, a change in response from 0 db to 0.1 db is inevitably associated with 10 deg. of phase shift. A change from 0 db to 3 db is always associated with a 45 deg. phase shift. It is instantly obvious that if these variations occur at the fundamental, they are substantially more at the harmonic frequencies and, therefore, the effect of feedback is reduced in proportion to the cosine of these phase shift angles. In some cases this may cause instability of the amplifier, particularly where large amounts of feedback are used.

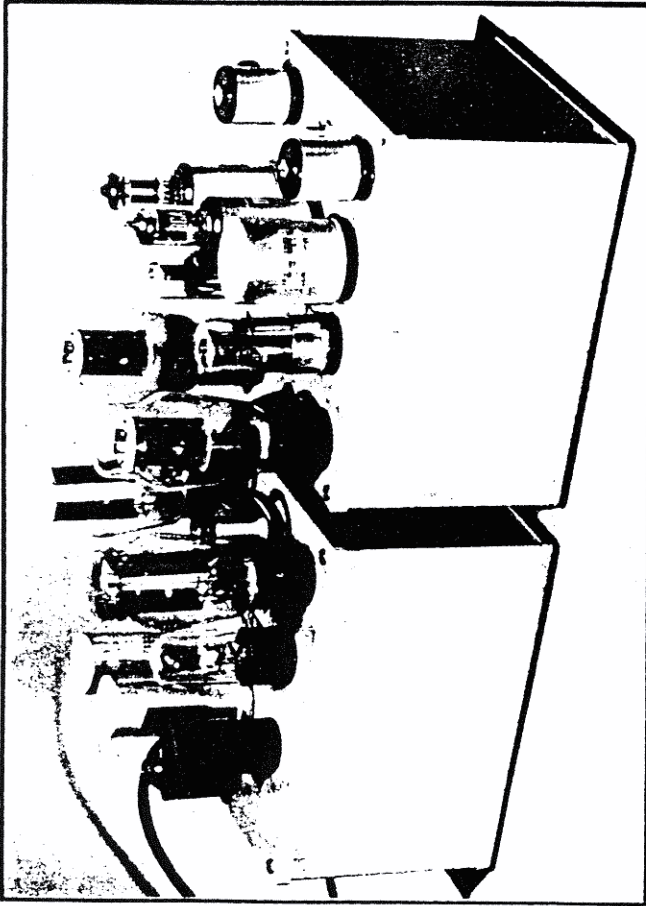

50 W-2 AMPLIFIER

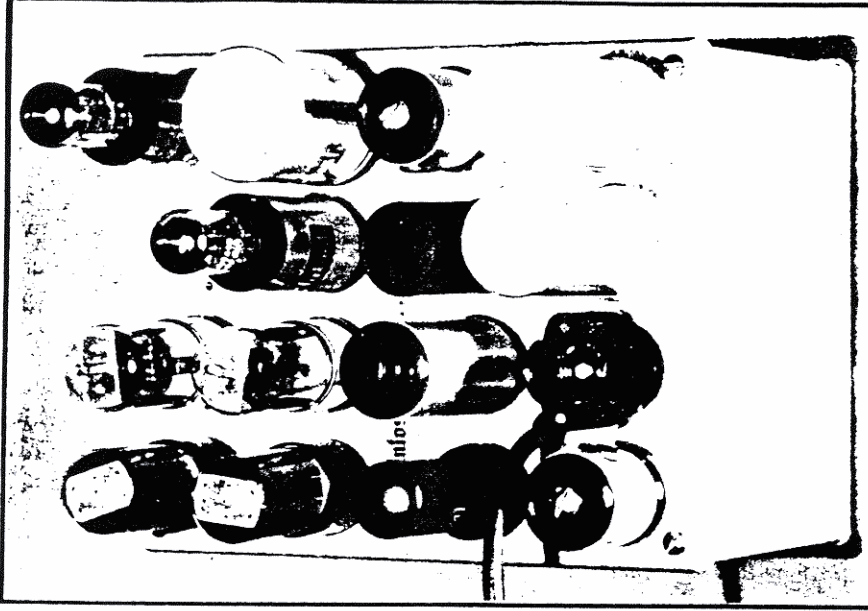

20 W-2 AMPLIFIER

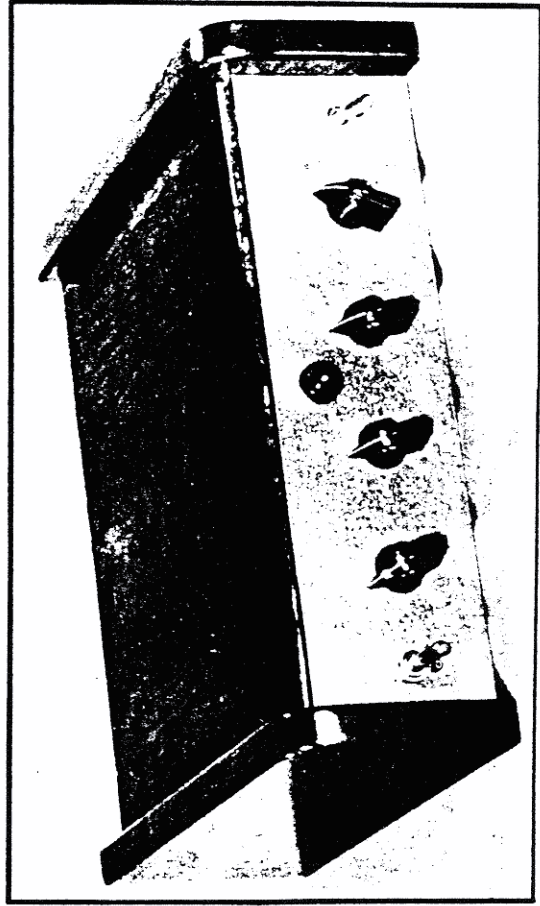

AE-2 AMPLIFIER EQUALIZER

McINTOSH ENGINEERING LABORATORY INC.

910 KING ST., SILVER SPRING, MARYLAND



AE-2 AMPLIFIER EQUALIZER FOR THE HOME

McINTOSH ENGINEERING LABORATORY presents the Model AE-2 Equalizer Amplifier Control after a year of development to bring about for the first time a stable, distortionless means of adjusting the bass and treble ends of the audio spectrum with no interaction between the various controls and complete freedom of transient distortion and amplifier instability. Several methods of equalizing were investigated and rejected because of inherent limitations. Four cathode coupled stages are used as well as four plate loaded stages to make this control truly an instrument of quality to be used with the unsurpassed McINTOSH amplifier now recognized as the world's finest. Following are a list of some of the features:

1. No increase in distortion when used with the McINTOSH amplifier. The unit will deliver 4 volts at less than 0.3% distortion over the audio range, 20 cycles to 20 kilocycles, for any setting of the equalizer.
2. Circuit arrangement and techniques provide complete freedom from impulse types of distortion. (Turning the unit on and off or changing the level suddenly will not cause amplifier flutter.)
3. Stable feedback amplification permits full adjustment of either the treble or bass controls without any amplifier instability whatsoever.
4. Minimum phase shift networks consistent with desired equalization.
5. Complete self-contained 60-cycle, 117-volt, power supply transformer and rectifier to make the unit independent of the amplifier to which it is connected.
6. Additional receptacle for connecting the amplifier so that the switch on the control unit will turn both the amplifier and control unit on and off.
7. Calibrated potentiometer settings to permit resetting of controls with the assurance that repeated characteristics will be obtained. +15 db (gain) and -20 db (loss) over flat zero settings.
8. 300 and 500 cycle turnovers at 6 db octave rate available by the flip of a switch.
9. Five input channels:

	Max. Input	Min. Input
1. Crystal pickup	20 Volts	.01 Volts
2. FM-AM tuner	20	.01
3. Pickering pickup	0.3	.01
4. G. E. pickup	0.3	.01
5. Low level microphone	0.3	.01

(20, .3 and .01 volts across 600 ohms would indicate approximately +28, -8 and -38 dbm respectively.)
10. Separate adjustable level controls for FM-AM tuner and crystal pickups.
11. Main volume control.
12. Plug-in amplifier stages to facilitate servicing.
13. Plug-in filter condensers (electrolytic).
14. Six-foot input power cord provided.
15. 10 inches wide, 10 1/4 inches deep, and 2 3/4 inches high basic unit overall dimensions.
16. Available in hammertone grey - wooden cabinet or book enclosure.

TO THE LISTENER: This instrument of quality provides for the control necessary to give ideal listening condition for normal levels of sound and is designed to accommodate practically all recordings now available. Instructions are included which give positive information on the settings of the various controls to compensate fully for the recording characteristics and to permit the adjustment of the mellowness or the brilliance to suit the discriminating individual. This unit used with the McINTOSH amplifier will give performance of unbelievable realism and provides the finest instrumentality for music and sound reproduction that electronic engineers have been able to devise up to this time.

McINTOSH ENGINEERING LABORATORY, INC.